

CONTINUE - SEE SHEET 3

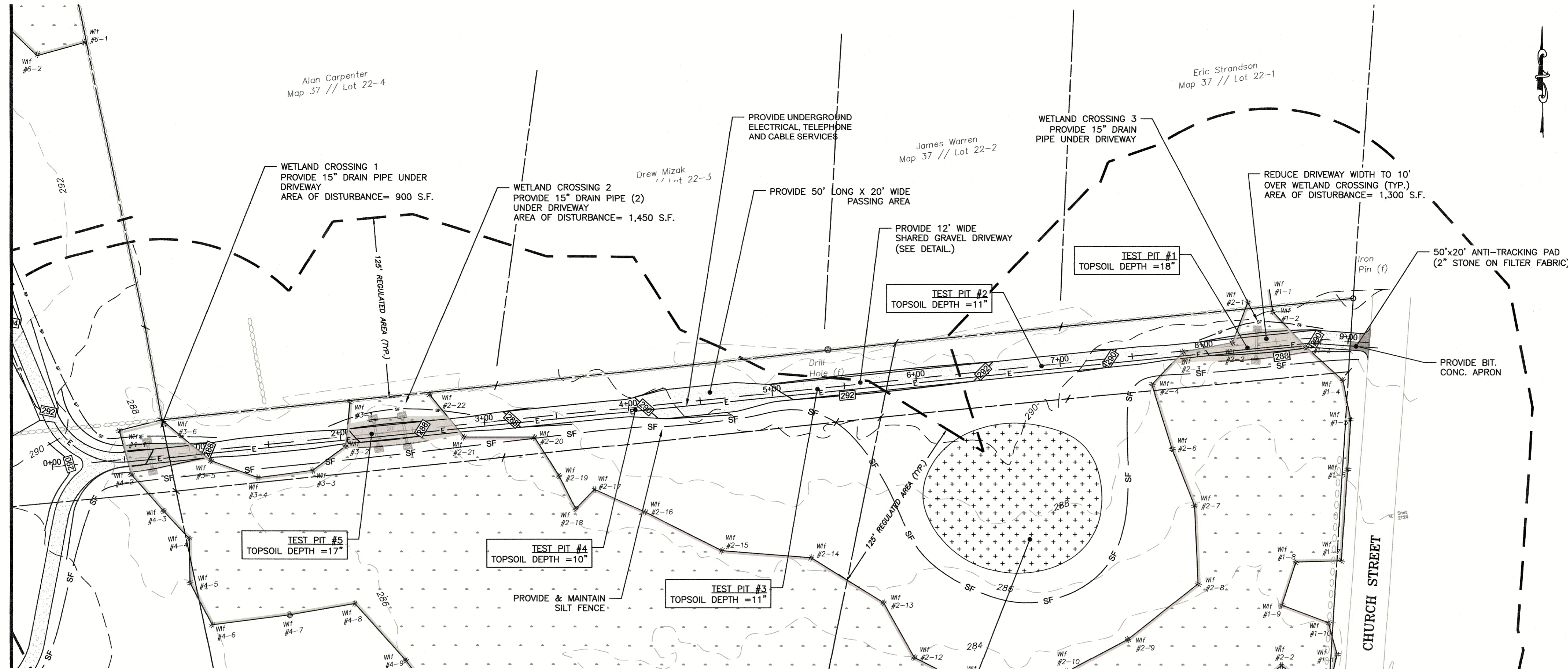

PLAN

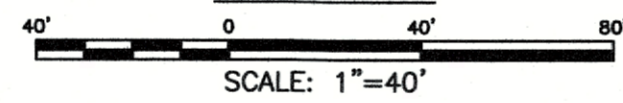

NOTE:
TEST HOLES IN PROPOSED DRIVEWAY WERE OBSERVED ON 5-18-21 AT THE APPROXIMATE LOCATIONS SHOWN ABOVE. INDICATIONS OF SEASONAL HIGH GROUNDWATER DEPTH WAS OBSERVED BETWEEN 0-16" IN WETLAND AREAS, AND 16" AND GREATER IN UPLAND AREAS.

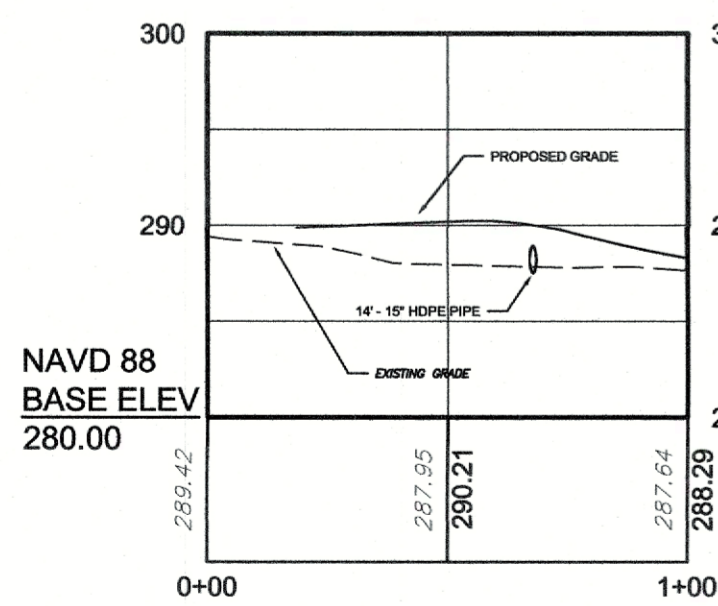

SHARED DRIVEWAY Wetland Crossing 1
STA 0+00 TO STA 1+00
Horiz. Scale= 1"= 40'
Vert. Scale= 1"= 10'

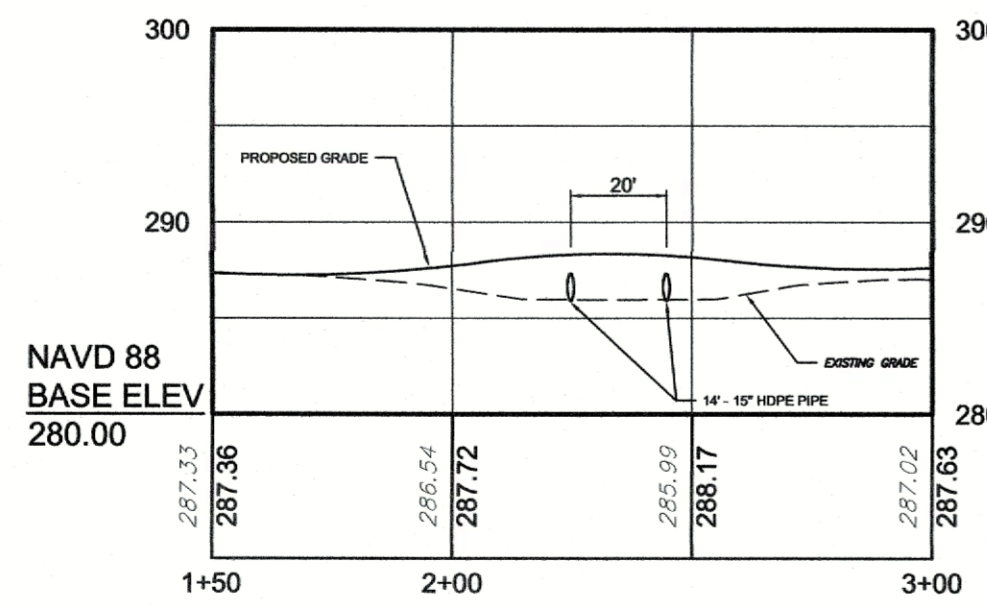

SHARED DRIVEWAY Wetland Crossing 2
STA 1+50 TO STA 3+00
Horiz. Scale= 1"= 40'
Vert. Scale= 1"= 10'

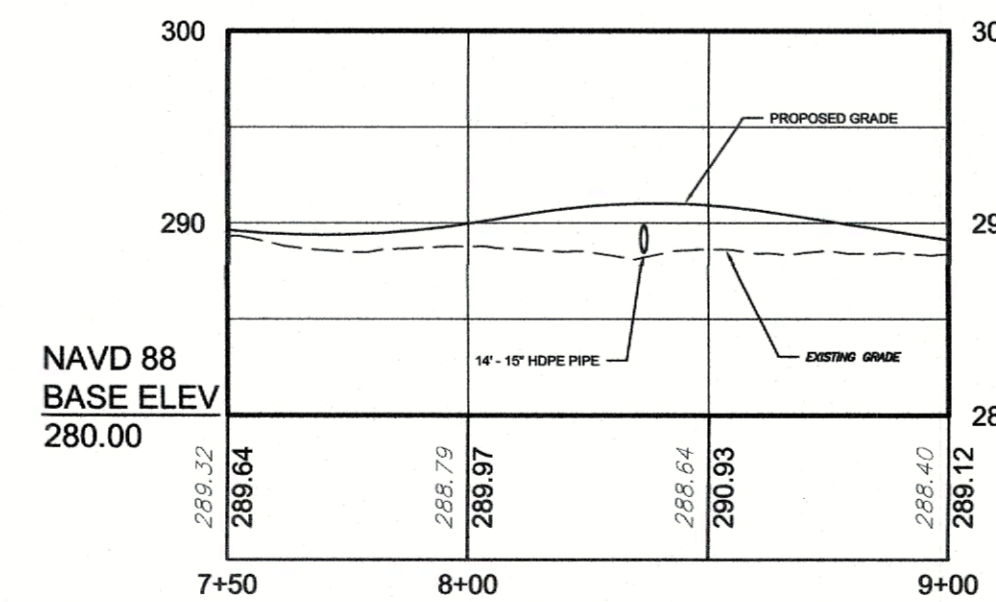

SHARED DRIVEWAY Wetland Crossing 3
STA 7+50 TO STA 9+00
Horiz. Scale= 1"= 40'
Vert. Scale= 1"= 10'

**Wetland Crossing (Typical)
Shared Driveway
Horiz. & Vert. Scale: 1" = 4'**

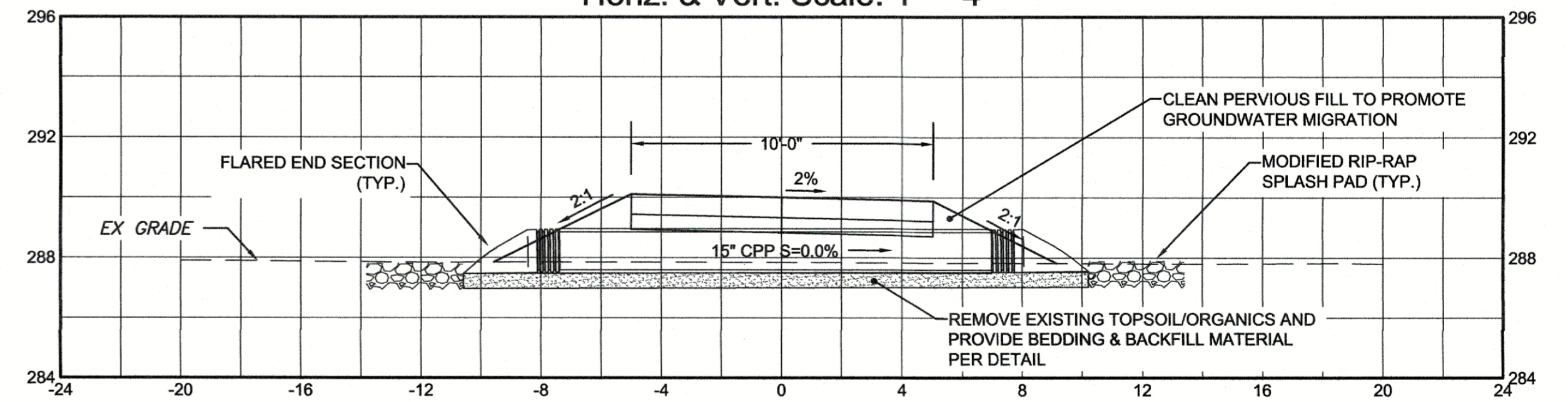

ARCHER Surveying LLC
18 Providence Road, Brooklyn, CT
(860) 779-2240

<p>CLA Engineers, Inc. CIVIL · STRUCTURAL · SURVEYING</p> <p>317 Main Street Norwich, CT 06360 (860) 886-1966 Fax (860) 886-9165</p>														
<table border="1"> <tr> <th>No.</th> <th>DATE</th> <th>REVISION</th> </tr> <tr> <td>3</td> <td>07/06/21</td> <td>MISCELLANEOUS REVISIONS</td> </tr> <tr> <td>2</td> <td>06/30/21</td> <td>VARIOUS MODIFICATIONS</td> </tr> <tr> <td>1</td> <td>05/10/21</td> <td>VARIOUS MODIFICATIONS</td> </tr> </table>	No.	DATE	REVISION	3	07/06/21	MISCELLANEOUS REVISIONS	2	06/30/21	VARIOUS MODIFICATIONS	1	05/10/21	VARIOUS MODIFICATIONS	<p>A. KAUSCH & SONS, LLC</p> <p>LOTS 019-37-17, 019-37-20 & 019-37-21 CHURCH ST. SITE DEVELOPMENT BROOKLYN, CT</p> <p>GRADING & SITE DESIGN</p>	
No.	DATE	REVISION												
3	07/06/21	MISCELLANEOUS REVISIONS												
2	06/30/21	VARIOUS MODIFICATIONS												
1	05/10/21	VARIOUS MODIFICATIONS												
<p>Project No. CLA-6639 Proj. Engineer R.A.D. Date: 04/30/21 Sheet No. 2 of 4</p>														

SELECT FILL SPECIFICATION

SELECT FILL PLACED WITHIN AND ADJACENT TO LEACHING SYSTEM AREAS SHALL BE COMPRISED OF CLEAN SAND, OR SAND AND GRAVEL, FREE FROM ORGANIC MATTER AND FOREIGN SUBSTANCES. THE SELECT FILL SHALL MEET THE FOLLOWING REQUIREMENTS PER THE CONNECTICUT PUBLIC HEALTH CODE FOR USE WITHIN THE LEACHING AREA:

1. THE SELECT FILL SHALL NOT CONTAIN ANY MATERIAL LARGER THAN THE THREE (3) INCH SLEEVE.
2. UP TO 45% OF THE DRY WEIGHT OF THE REPRESENTATIVE SAMPLE MAY BE RETAINED ON THE #4 SLEEVE (THIS IS THE GRAVEL PORTION OF THE SAMPLE).
3. THE MATERIAL THAT PASSES THE #4 SIEVE IS THEN REWEIGHED AND THE SIEVE ANALYSIS STARTED.
4. THE REMAINING SAMPLE SHALL MEET THE FOLLOWING CRITERIA:

SIEVE SIZE	PERCENT PASSING WET SIEVE	DRY SIEVE
#4	100	100
#10	70-100	70-100
#40	10-50*	10-75
#100	0-20	0-5
#200	0-5	0-2.5

* PERCENT PASSING THE #40 SIEVE CAN BE INCREASED TO NO GREATER THAN 75 IF THE PERCENT PASSING THE #100 SIEVE DOES NOT EXCEED 10 AND THE #200 SIEVE DOES NOT EXCEED 5.

SEPTIC NOTES

1. PROPOSED SEPTIC SYSTEM TO BE STAKED IN THE FIELD BY A LAND SURVEYOR LICENSED IN THE STATE OF CONNECTICUT.
2. A BENCHMARK SHALL BE SET WITHIN 10'-15' OF THE PROPOSED SEPTIC SYSTEM PRIOR TO CONSTRUCTION.
3. ALL WORK AND MATERIAL (SEPTIC TANK, DISTRIBUTION BOX, PIPE) SHALL CONFORM TO THE CONNECTICUT PUBLIC HEALTH CODE REGULATIONS AND STANDARDS FOR SUBSURFACE SEWAGE DISPOSAL SYSTEM.
4. SEWER LINE FROM FOUNDATION WALL TO SEPTIC TANK SHALL BE 4" SCHEDULE 40 PVC - ASTM D 1785 AND JOINTS PER HEALTH DEPT. CODE.
5. PIPE FROM SEPTIC TANK TO DISTRIBUTION LINES SHALL BE 4" SOLID PVC CONFORMING TO ASTM D 3034 AND SDR-35.
6. SYSTEMS SHALL BE SET LEVEL FOR ENTIRE LENGTH AND HAVE A CENTER TO CENTER SPACING AS CALLED FOR IN THE CONNECTICUT PUBLIC HEALTH CODE. THERE ARE PRESENTLY NO KNOWN WATER WELLS WITHIN 75' OF THE PROPOSED SEPTIC SYSTEMS.
7. CLEAR AND GRUB THE AREA WHERE THE SEPTIC SYSTEMS AND HOUSES ARE TO BE CONSTRUCTED. ALL TOPSOIL IS TO BE STRIPPED AND STOCKPILED FOR FUTURE USE.
8. ALL FILL MATERIAL SHALL BE CLEAN EARTH FREE OF STUMPS, ORGANICS, CONSTRUCTION DEBRIS AND TOPSOIL.
9. TOPSOIL SHALL BE RE-APPLIED OVER ALL FILL AREAS AND ALL DISTURBED AREAS TO PROVIDE A MINIMUM DEPTH OF FOUR INCHES IN ACCORDANCE WITH THE SLOPE STABILIZATION DETAILS.

DEEP TEST PIT DATA / SOIL DESCRIPTIONS

PERFORMED BY: Donovan Moe
 WITNESSED BY: NORTHEAST DISTRICT DEPARTMENT OF HEALTH DATE: 03/30/2021

TEST PIT: 1	TEST PIT: 2
0" - 10" Topsoil / Organics	0" - 10" Topsoil / Organics
10" - 16" Orange Brown Fine Sand Loam	10" - 27" Dark Brown Fine Sand
16" - 34" Tan Compact Sand Loam	27" - 48" Grey Compact Sand
34" - 78" Grey Sand & Gravel	48" - 70" Sand & Gravel
MOTTLES: 36"	MOTTLES: 32"
GROUNDWATER: 66"	GROUNDWATER: 62"
LEDGE: NO	LEDGE: NO
ROOTS: 46"	ROOTS: 32"
RESTRICTIVE: NO	RESTRICTIVE: NO

TEST PIT: 3	TEST PIT: 4
0" - 12" Topsoil / Organics	0" - 10" Topsoil / Organics
12" - 30" Tan Orange Fine Sand Loam	10" - 24" Tan Orange Fine Sand Loam
30" - 48" Grey Sand Layer	24" - 80" Saturated Grey Sand & Gravel
48" - 72" Sand & Gravel	
MOTTLES: 30"	MOTTLES: 28"
GROUNDWATER: 65"	GROUNDWATER: 74"
LEDGE: NO	LEDGE: NO
ROOTS: NO	ROOTS: 30"
RESTRICTIVE: NO	RESTRICTIVE: NO

PERCOLATION DATA
 PERC 1 - DEPTH 23"

TIME	DROP (INCHES)
11:10	6.0
11:12	7.0
11:14	8.0
11:16	8.5
11:18	9.25
11:20	9.5
11:22	10.0
11:25	11.0
11:28	11.5
11:31	12.0

PERCOLATION RATE > 6.0 MIN./IN.
 NOTES:
 PERCOLATION TEST PERFORMED ON 3/30/2021
 PERFORMED BY Donovan Moe

PERCOLATION DATA
 PERC 2 - DEPTH 17"

TIME	DROP (INCHES)
11:04	6.25
11:10	8.25
11:16	9.75
11:22	10.625
11:34	12.125
11:46	13.125
11:58	14.625

PERCOLATION RATE > 8.0 MIN./IN.
 NOTES:
 PERCOLATION TEST PERFORMED ON 3/30/2021
 PERFORMED BY Donovan Moe

CONCEPT SEPTIC SYSTEM DESIGN

PROPOSED LOT 1
 PRIMARY LEACHING AREA
 4 BEDROOM RESIDENCE
 PERCOLATION RATE: 8.0 MIN./INCH (NDDH FILE #21000307)
 LEACHING AREA REQUIRED: 557.5 SF

USE TRADITIONAL TRENCH
 EFFECTIVE LEACHING AREA OF LEACHING TRENCH 3.0 SF/LF
 REQUIRED LENGTH = 557.5 SF / 3 SF/LF = 186 LF

M.L.S.S. CALCULATION
 HYDRAULIC FACTORS
 DEPTH TO RESTRICTIVE LAYER = 32"
 SLOPE = 6.0%
 HYDRAULIC FACTOR (HF) = 32
 FLOW FACTOR (FF) = 1.0
 PERCOLATION FACTOR (PF) = 1.75 (LESS THAN 10.0 MIN./INCH)
 M.L.S.S. REQUIRED: 32 x 1.0 x 1.75 = 56 LF

PROPOSED SYSTEM
 USE 3 ROWS OF 65 LF
 LEACHING AREA PROVIDED = 585 SF

RESERVE LEACHING AREA
 USE SAME AS PRIMARY SYSTEM

PROPOSED LOT 2
 PRIMARY LEACHING AREA
 4 BEDROOM RESIDENCE
 PERCOLATION RATE: 8.0 MIN./INCH (NDDH FILE #21000307)
 LEACHING AREA REQUIRED: 557.5 SF

USE TRADITIONAL TRENCH
 EFFECTIVE LEACHING AREA OF LEACHING TRENCH 3.0 SF/LF
 REQUIRED LENGTH = 557.5 SF / 3 SF/LF = 186 LF

M.L.S.S. CALCULATION
 HYDRAULIC FACTORS
 DEPTH TO RESTRICTIVE LAYER = 28"
 SLOPE = 4.0%
 HYDRAULIC FACTOR (HF) = 34
 FLOW FACTOR (FF) = 1.0
 PERCOLATION FACTOR (PF) = 1.75 (LESS THAN 10.0 MIN./INCH)
 M.L.S.S. REQUIRED: 34 x 1.0 x 1.75 = 59.5 LF

PROPOSED SYSTEM
 USE 3 ROWS OF 65 LF
 LEACHING AREA PROVIDED = 585 SF

RESERVE LEACHING AREA
 USE SAME AS PRIMARY SYSTEM

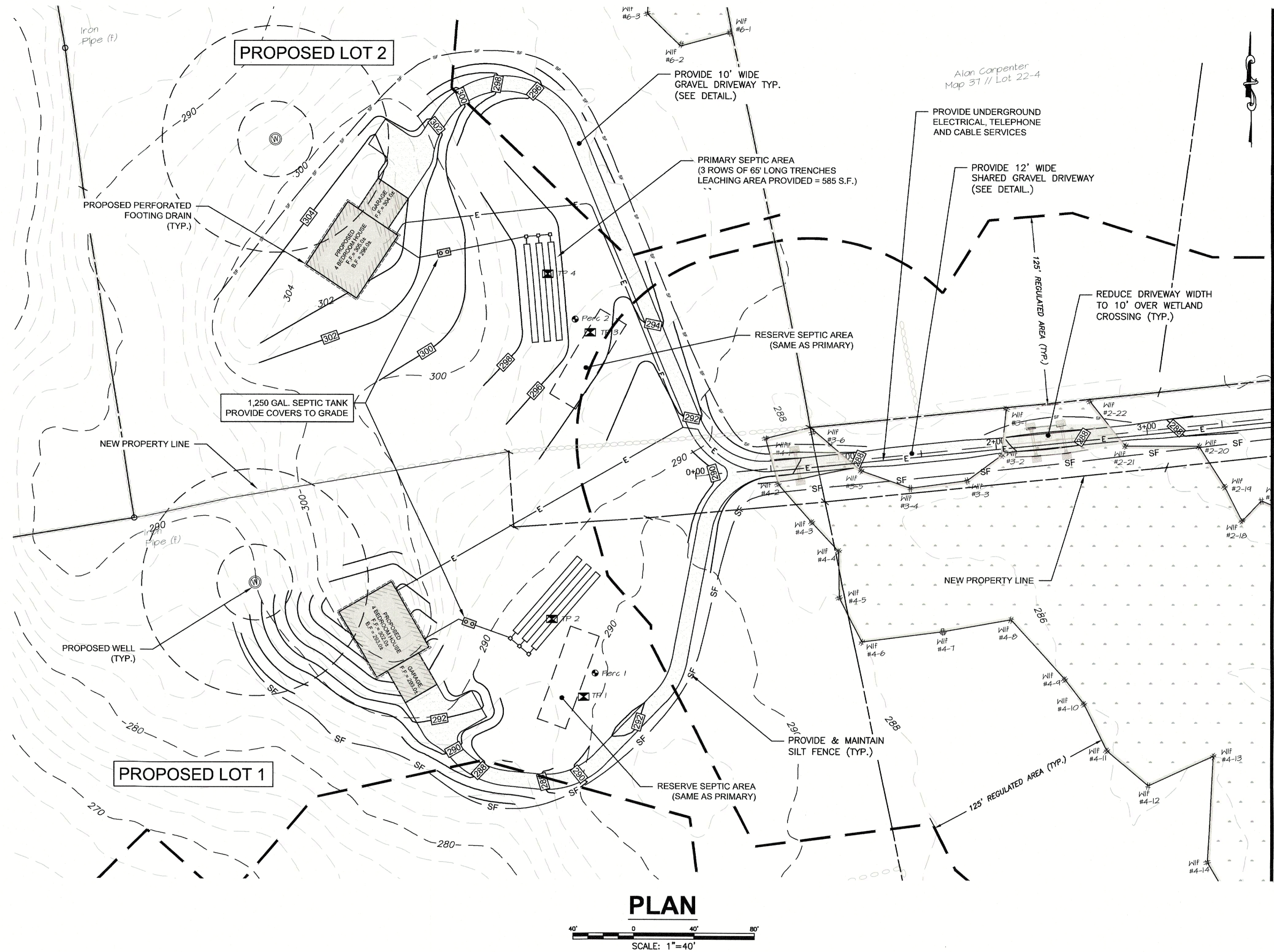

CONTINUE - SEE SHEET 2



ARCHER Surveying LLC
 18 Providence Road, Brooklyn, CT
 (860) 779-2240

<p>CLA Engineers, Inc. CIVIL • STRUCTURAL • SURVEYING</p> <p>317 Main Street Norwich, CT 06360 (860) 886-1966 Fax (860) 886-9165</p>		<p>Project No. CLA-6639</p> <p>Proj. Engineer R.A.D.</p> <p>Date: 04/30/21</p> <p>Sheet No. 3 of 4</p>
<p>2 08/30/21 VARIOUS MODIFICATIONS</p> <p>1 05/10/21 VARIOUS MODIFICATIONS</p>	<p>A. KAUSCH & SONS, LLC</p> <p>LOTS 019-37-17, 019-37-20 & 019-37-21 CHURCH ST. SITE DEVELOPMENT BROOKLYN, CT</p> <p>GRADING & SITE DESIGN</p>	

EROSION & SEDIMENTATION CONTROL NARRATIVE

- THE EROSION & SEDIMENTATION CONTROL PLAN AND DETAILS HAVE BEEN DEVELOPED AS A STRATEGY TO CONTROL SOIL EROSION AND SEDIMENTATION DURING AND AFTER CONSTRUCTION. THIS PLAN IS BASED ON THE "2002 CONNECTICUT GUIDELINES FOR SOIL EROSION AND SEDIMENT CONTROL" BY THE CONNECTICUT COUNCIL ON SOIL AND WATER CONSERVATION IN COOPERATION WITH THE CONNECTICUT DEP.
- THE PROPOSED LOCATIONS OF SILTATION AND EROSION CONTROL MEASURES ARE SHOWN ON THE PLANS. THE CONTRACTOR SHALL PROVIDE SILT FENCE, STONE CHECK DAMS AND/OR OTHER EROSION CONTROL MEASURES AS NEEDED OR DIRECTED BY THE ENGINEER OR TOWN STAFF TO ADEQUATELY PREVENT SEDIMENT TRANSPORT.
- EROSION AND SEDIMENTATION CONTROL MEASURES SHALL BE INSTALLED PRIOR TO SITE DISTURBANCE.
- THE CONTRACTOR SHALL INSPECT, REPAIR AND/OR REPLACE EROSION CONTROL MEASURES EVERY 7 DAYS AND IMMEDIATELY FOLLOWING ANY SIGNIFICANT RAINFALL OR SNOW MELT. SEDIMENT DEPOSITS MUST BE REMOVED WHEN WHEN DEPOSITS REACH APPROXIMATELY ONE HALF THE HEIGHT OF THE BARRIER. SEDIMENT CONTROL DEVICES SHALL REMAIN IN PLACE AND BE MAINTAINED BY THE CONTRACTOR UNTIL AREAS UPSLOPE ARE PERMANENTLY STABILIZED.
- STAKED HAY BALE SILT BARRIERS OR SILT FENCE SHALL BE INSTALLED AROUND ANY TEMPORARY STOCKPILE AREAS. TEMPORARY VEGETATIVE COVER MAY BE REQUIRED (SEE NOTE).
- INLET SEDIMENTATION CONTROL DEVICES SHALL BE INSTALLED UNDER THE GRATES OF ALL NEW CATCH BASINS AT THE TIME OF INSTALLATION, AND UNDER THE GRATES OF EXISTING CATCH BASINS IN THE CONSTRUCTION AREA.
- CONTINUOUS DUST CONTROL USING WATER, CALCIUM CHLORIDE OR APPROVED EQUAL SHALL BE PROVIDED FOR ALL EARTH STOCKPILES, EARTH PILED ALONG EXCAVATIONS, SURFACES OF BACKFILLED TRENCHES AND GRAVELED ROADWAY SURFACES.
- IF DEWATERING IS NECESSARY DURING ANY TIME OF CONSTRUCTION A CLEAR WATER DISCHARGE SHALL BE PROVIDED AS SHOWN IN THE HAY-BALE BARRIER DEWATERING DETAIL OR ALTERNATE METHOD PROPOSED BY THE CONTRACTOR AND APPROVED BY THE ENGINEER.
- ALL DISTURBED AREAS SHALL BE RESTORED PER THE SLOPE STABILIZATION AND PERMANENT VEGETATION DETAILS. ALL DISTURBED AREAS THAT ARE SLOPED LESS THAN THREE HORIZONTAL TO ONE VERTICAL (3:1) SLOPE SHALL BE LOAMED, SEED, FERTILIZED AND MULCHED PER THE PERMANENT VEGETATIVE COVER SPECIFICATIONS. EROSION CONTROL MATTING SHALL BE PROVIDED ON ALL DISTURBED AREAS THAT ARE SLOPED MORE THAN THREE HORIZONTAL TO ONE VERTICAL (3:1).
- IF FINAL SEEDING OF DISTURBED AREAS IS NOT TO BE COMPLETED BEFORE OCTOBER 15, THE CONTRACTOR SHALL PROVIDE TEMPORARY MULCHING (DORMANT SEEDING MAY BE ATTEMPTED AS WELL) TO PROTECT THE SITE AND DELAY PERMANENT SEEDING.
- WHEN FEASIBLE, TEMPORARY SEEDING OF DISTURBED AREAS THAT HAVE NOT BEEN FINISHED GRADED SHALL BE COMPLETED PRIOR TO OCTOBER 15.
- ANY EROSION WHICH OCCURS WITHIN THE DISTURBED AREAS SHALL BE IMMEDIATELY REPAIRED AND STABILIZED. DURING THE CONSTRUCTION PHASE, INTERCEPTED SEDIMENT SHALL BE RETURNED TO THE SITE. POST SEEDING, INTERCEPTED SEDIMENT, IF ANY, SHALL BE DISPOSED OF IN A MANNER APPROVED BY THE TOWN AND ENGINEER.
- EROSION AND SEDIMENTATION CONTROL MEASURES SHALL REMAIN IN PLACE UNTIL VEGETATION IS RE-ESTABLISHED OR SLOPES ARE STABILIZED AND REMOVAL IS APPROVED BY THE TOWN.
- UNFORESEEN PROBLEMS WHICH ARE ENCOUNTERED IN THE FIELD SHALL BE SOLVED ACCORDING TO THE "2002 CONNECTICUT GUIDELINES FOR SOIL EROSION AND SEDIMENT CONTROL" BY THE CONNECTICUT COUNCIL ON SOIL AND WATER CONSERVATION IN COOPERATION WITH THE CONNECTICUT DEP.
- THE CONTRACTOR SHALL PROVIDE THE NAME AND EMERGENCY CONTACT INFORMATION FOR THE PROJECT PERSONNEL RESPONSIBLE FOR EROSION AND SEDIMENTATION CONTROLS PRIOR TO THE START OF CONSTRUCTION.

NOTE: THE CONTRACTOR SHALL CONTINUALLY STORE THE FOLLOWING MATERIALS ON SITE DURING CONSTRUCTION TO MEET UNEXPECTED EROSION NEEDS

- 100 LF OF SILT FENCE
- 10 HAY BALES
- 10 CY OF WOOD CHIPS OR CRUSHED STONE

TEMPORARY VEGETATIVE COVER

A TEMPORARY SEEDING OF RYE GRASS WILL BE COMPLETED WITHIN 15 DAYS OF THE FORMATION OF STOCKPILES. IF THE SOIL IN THE STOCKPILES HAS BEEN COMPACTED BY CONSTRUCTION OPERATIONS IT SHALL BE LOOSENE TO A DEPTH OF 2 INCHES BEFORE THE FERTILIZER, LIME AND SEED IS APPLIED. 10-10-10 FERTILIZER AT A RATE OF 7.5 POUNDS PER 1000 S.F. LIME AT A RATE OF 90 LBS. PER 1000 S.F. SHALL BE USED. RYE GRASS APPLIED AT A RATE OF 1 LB. PER 1000 S.F. SHALL PROVIDE THE TEMPORARY VEGETATIVE COVER. STRAW FREE FROM WEEDS AND COARSE MATTER SHALL BE USED AT A RATE OF 70-90 LBS. PER 1000 S.F. AS A TEMPORARY MULCH. APPLY MULCH AND DRIVE TRACKED EQUIPMENT UP AND DOWN SLOPE OVER ENTIRE SURFACE SO CLEAT MARKS ARE PARALLEL TO THE CONTOURS.

PERMANENT VEGETATIVE COVER

TOPSOIL WILL BE REPLACED ONCE THE EXCAVATIONS HAVE BEEN COMPLETED AND THE SLOPES ARE GRADED AS SHOWN ON THE PLANS. PROVIDE SLOPE PROTECTION AS CALLED FOR ON THE PLANS AND DETAILS. TOPSOIL SHALL BE SPREAD AT A MINIMUM COMPACTED DEPTH OF 4 INCHES. ONCE THE TOPSOIL HAS BEEN SPREAD, ALL STONES TWO INCHES OR LARGER IN ANY DIMENSION WILL BE REMOVED AS WELL AS DEBRIS.

- APPLY AGRICULTURAL GROUND LIME AT THE RATE OF TWO TONS PER ACRE OR 100 LBS. PER 1000 S.F.
- APPLY 10-10-10 FERTILIZER OR EQUIVALENT AT A RATE OF 300 LBS. PER ACRE OR 7.5 LBS. PER 1000 S.F.
- WORK LIME AND FERTILIZER INTO THE SOIL TO A DEPTH OF 4 INCHES.
- INSPECT SEEDBED BEFORE SEEDING.
- IF TRAFFIC HAS COMPACTED THE SOIL, RETILL COMPACTED AREAS.
- APPLY THE FOLLOWING GRASS SEED MIX:

TYPICAL SEED MIXTURE

ALL DISTURBED AREAS	LBS./ACRE	LBS./1000 S.F.
KENTUCKY BLUEGRASS	20	0.45
CREeping RED FESCUE	20	0.45
PERENNIAL RYEGRASS	5	0.10
	45	1.00

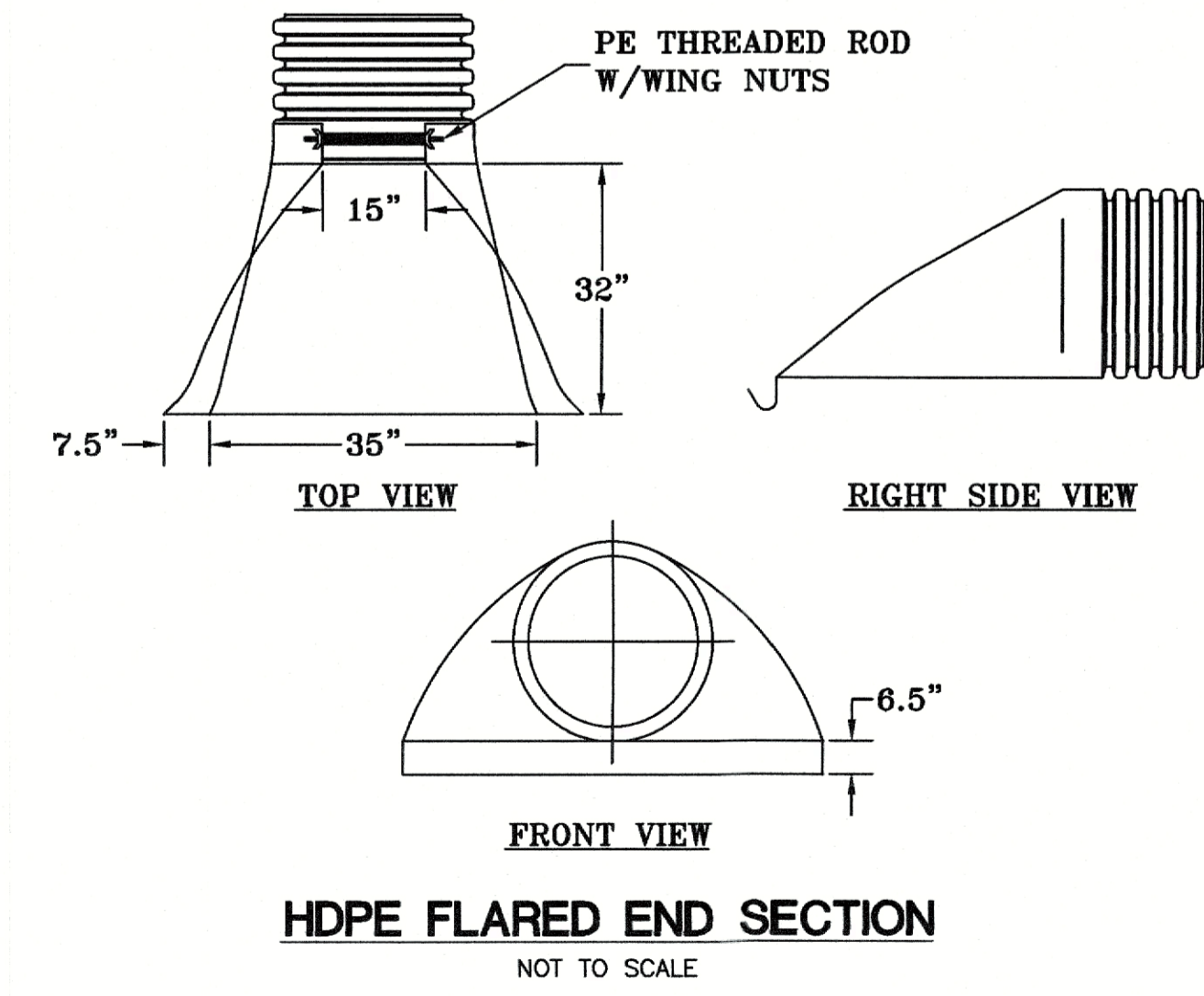
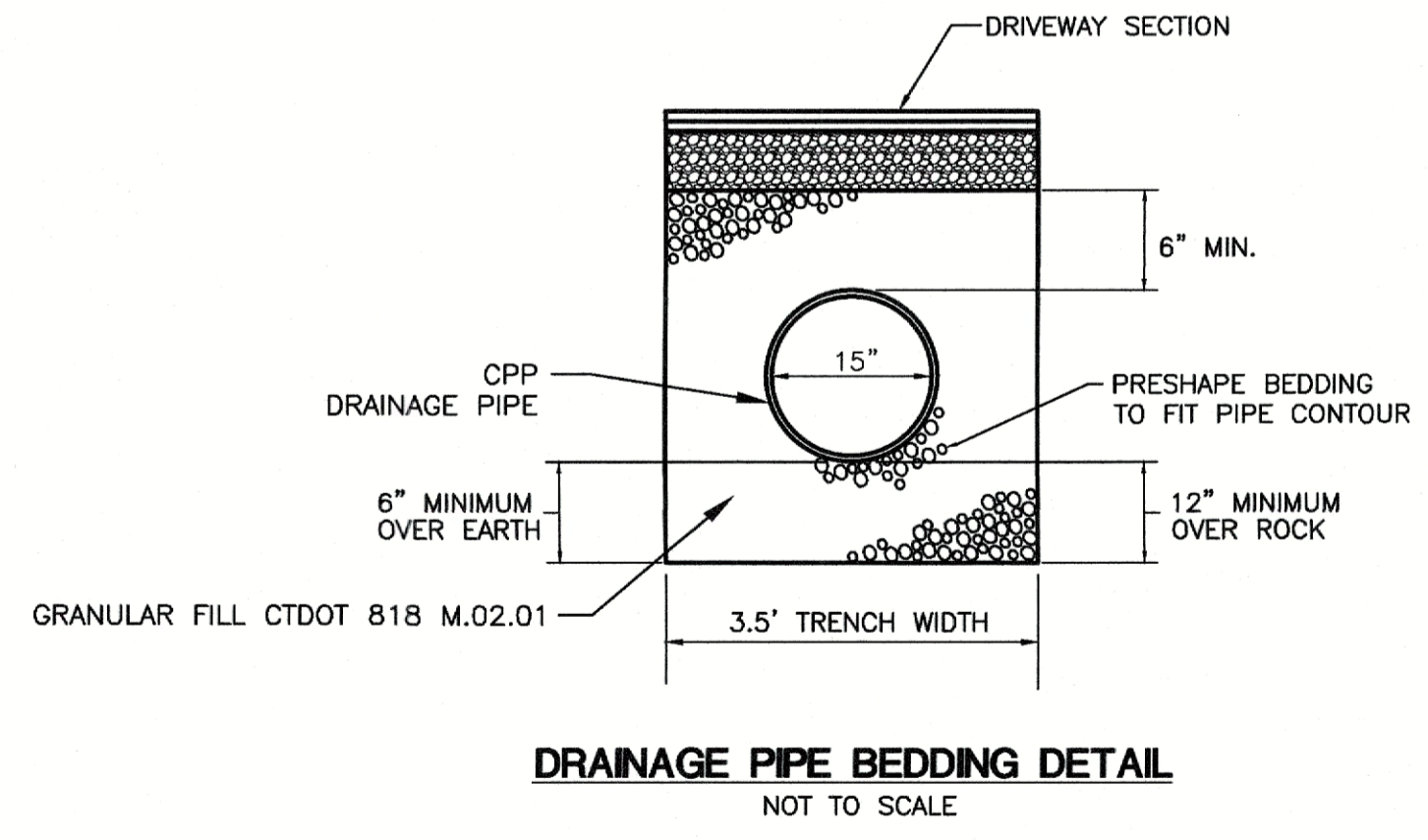
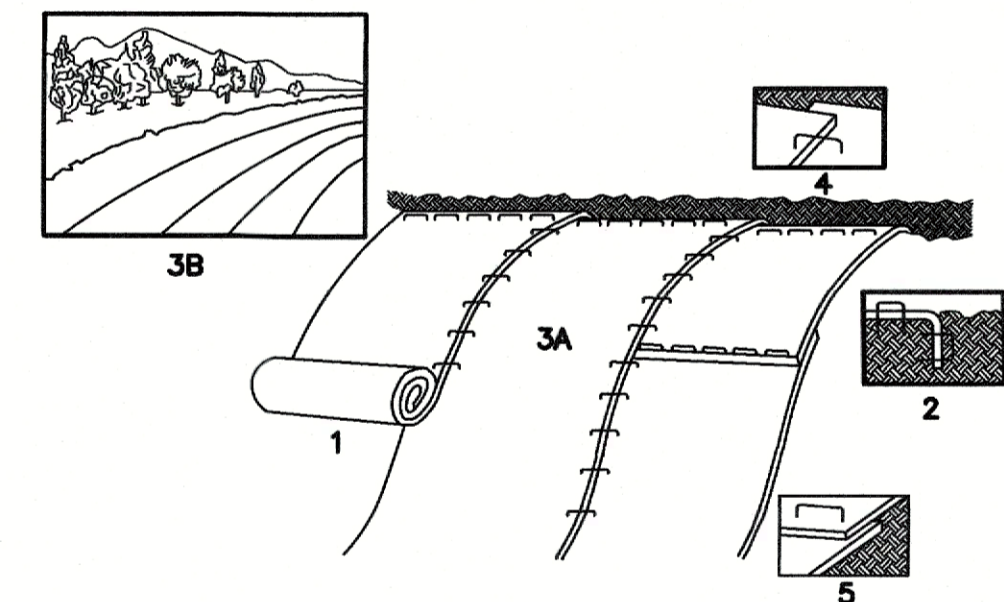
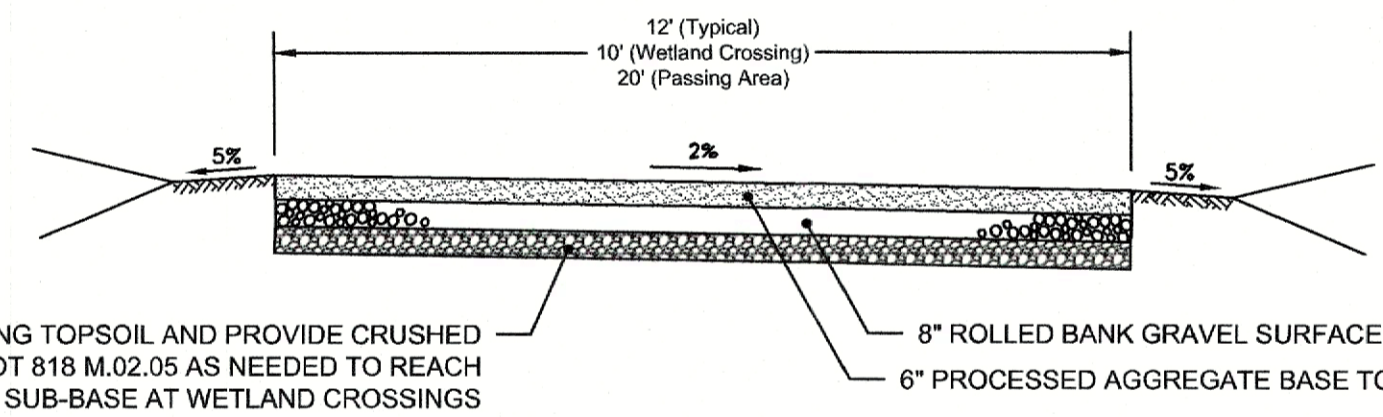
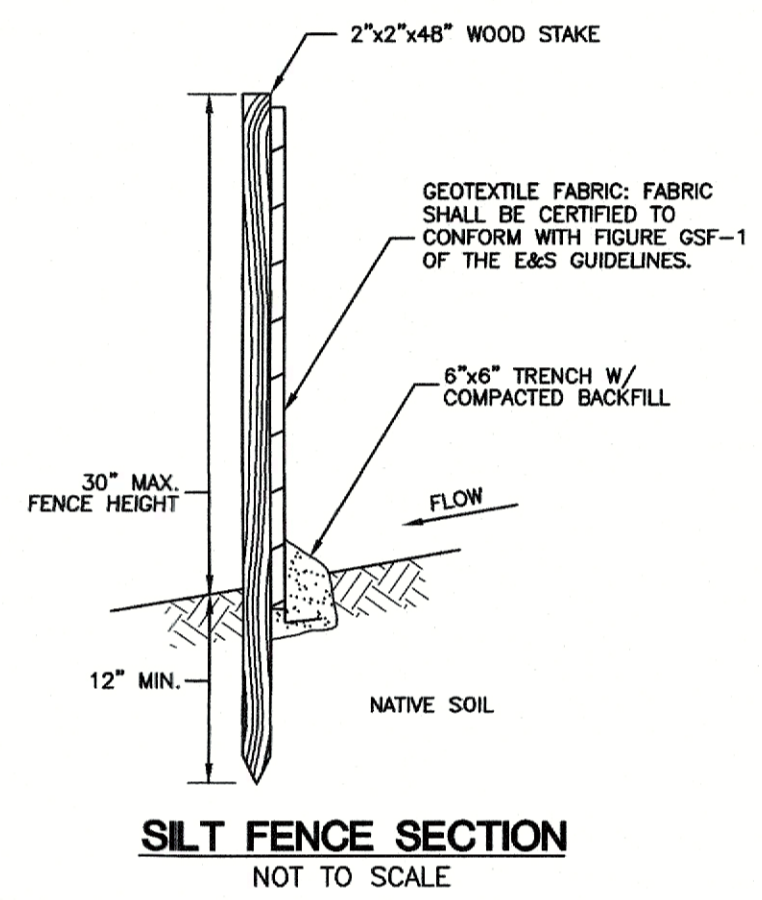
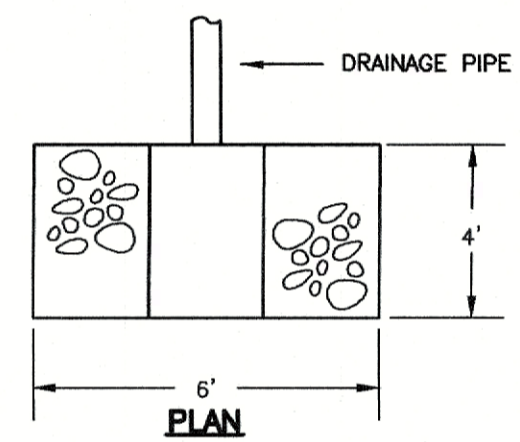
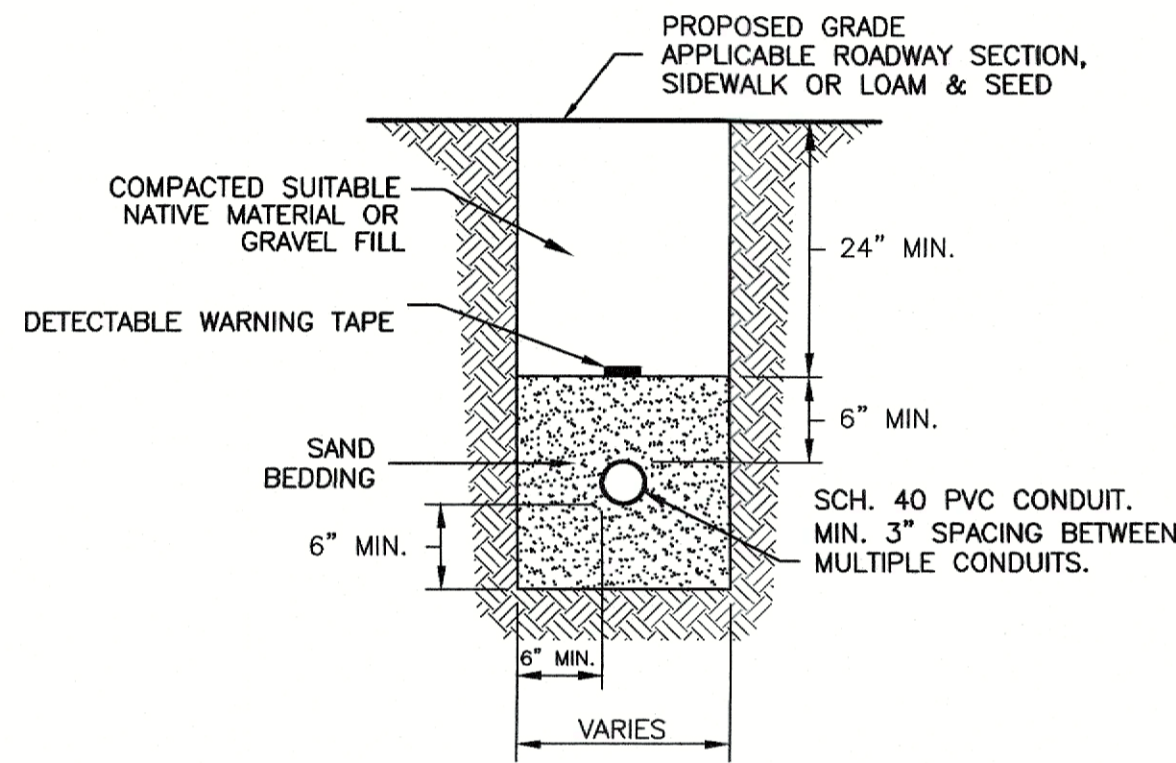
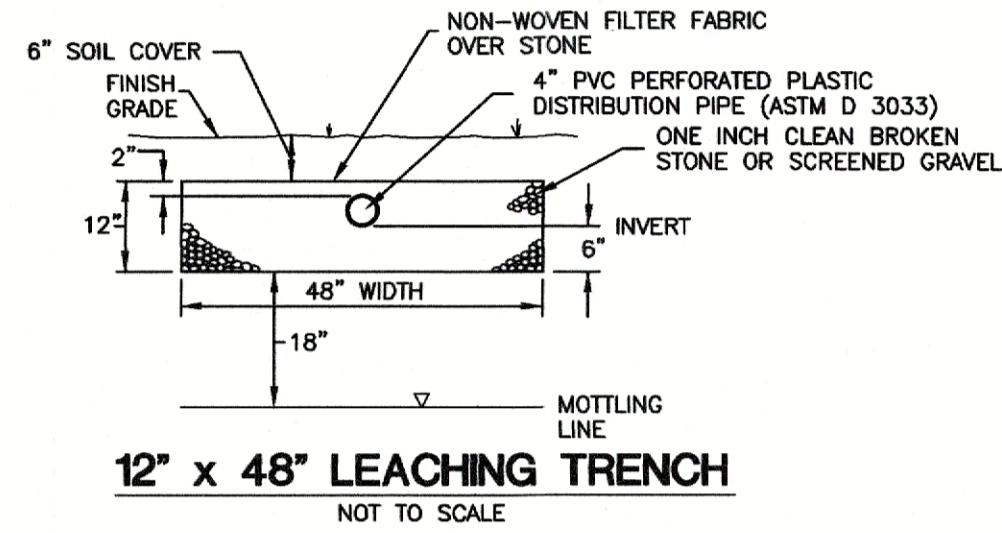
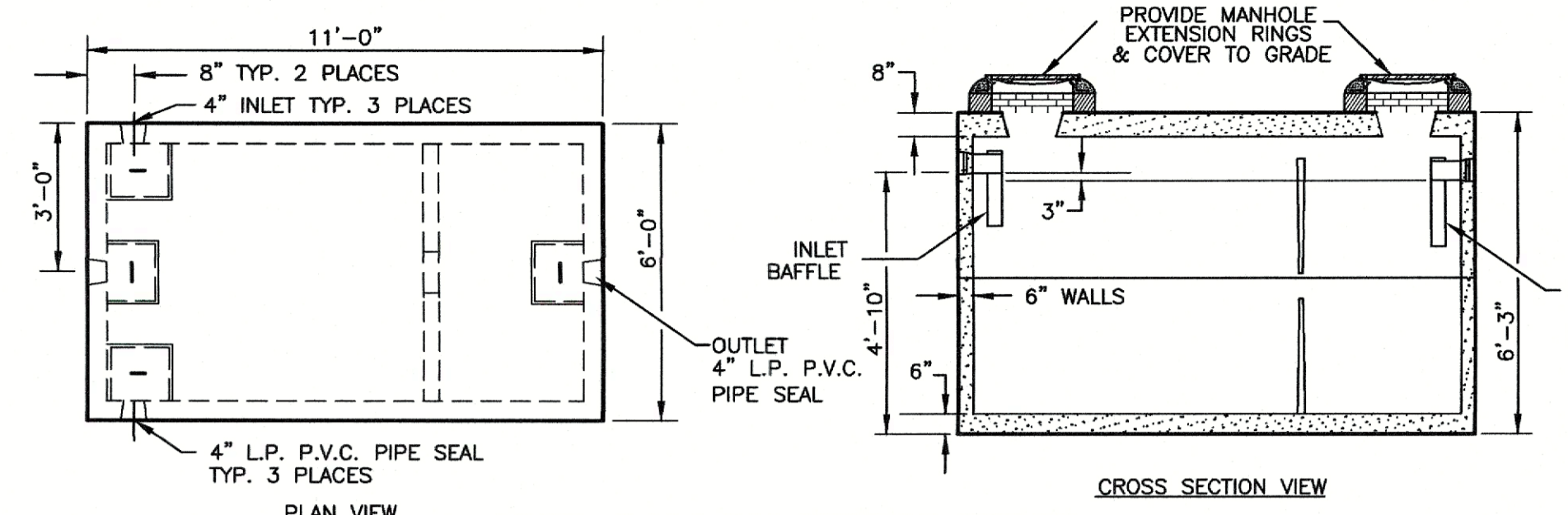
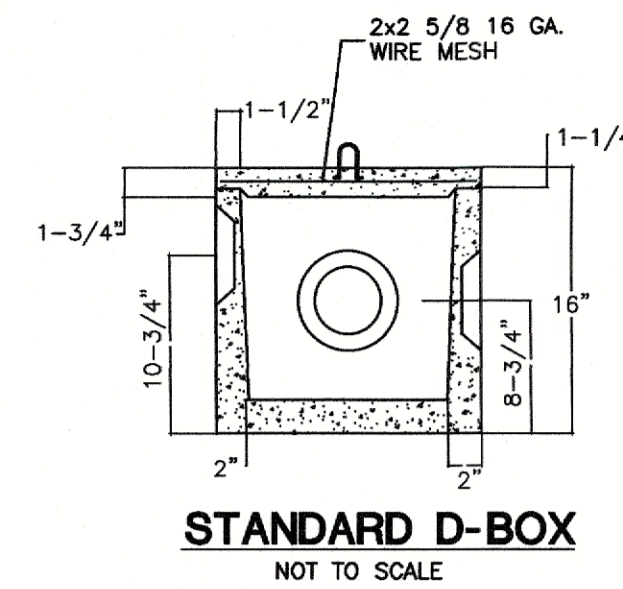

- PROVIDE 4" THICKNESS OF TOPSOIL OVER CLEAN FILL. PREPARE SOIL BEFORE INSTALLING BLANKETS, INCLUDING APPLICATION OF LIME, FERTILIZER, AND SEED MIX PER PERMANENT VEGETATIVE COVER NOTES. (SHALL BE PAID FOR AT THE UNIT PRICE FOR LOAM, SEED, FERTILIZE & MULCH)
- BEGIN AT THE TOP OF THE SLOPE BY ANCHORING THE BLANKET IN 6" DEEP x 6" WIDE TRENCH, BACKFILL AND COMPACT THE TRENCH AFTER STAPLING.
- ROLL THE BLANKET (A) DOWN OR (B) HORIZONTALLY ACROSS THE SLOPE.
- THE EDGES OF PARALLEL BLANKETS MUST BE STAPLED WITH APPROXIMATELY 2" OVERLAP.
- WHEN BLANKETS MUST BE SPICED DOWN THE SLOPE, PLACE BLANKETS END OVER END (SHINGLE STYLE) WITH APPROXIMATELY 4" OVERLAP. STAPLE THROUGH OVERLAPPED AREA, APPROXIMATELY 12" APART.

EROSION CONTROL MATTING DETAIL (FOR 3:1 SLOPES OR GREATER)

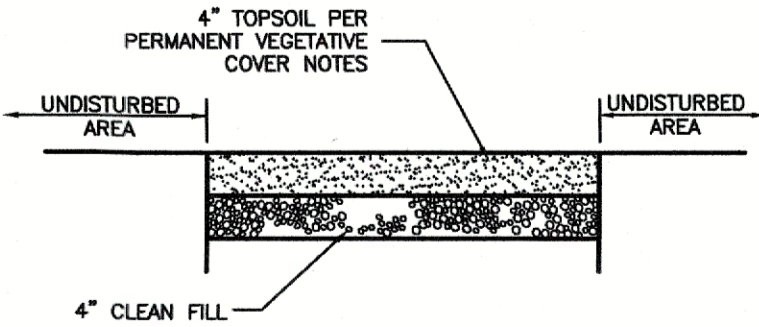

TYPICAL LOAM & SEED SECTION DETAIL (FOR ALL DISTURBED AREAS)

ARCHER Surveying LLC
18 Providence Road, Brooklyn, CT
(860) 779-2240

CLA Engineers, Inc.
CIVIL • STRUCTURAL • SURVEYING
317 Main Street Norwich, CT 06380
(860) 886-1986 Fax (860) 886-9165

A. KAUSCH & SONS, LLC
Project No. CLA-6659
Proj. Engineer R.A.D.
Date: 04/30/21
Sheet No. 4 of 4

LOTS 019-37-17, 019-37-20 & 019-37-21
CHURCH ST. SITE DEVELOPMENT
BROOKLYN, CT

NOTES & CONSTRUCTION DETAILS